

Continuous Extrusion Shuttle Blow Molding Machine

For Production of Plastic Containers

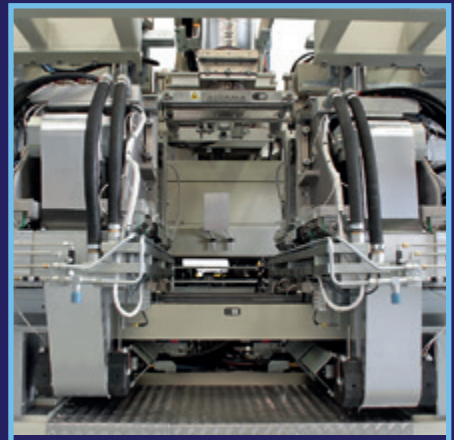
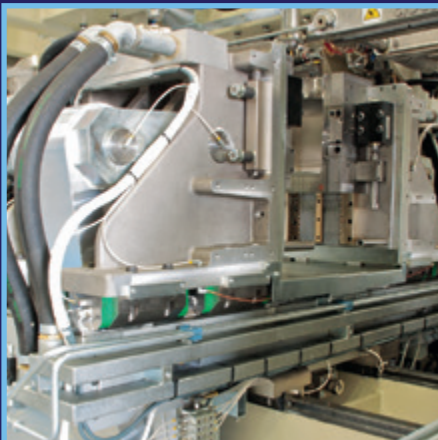
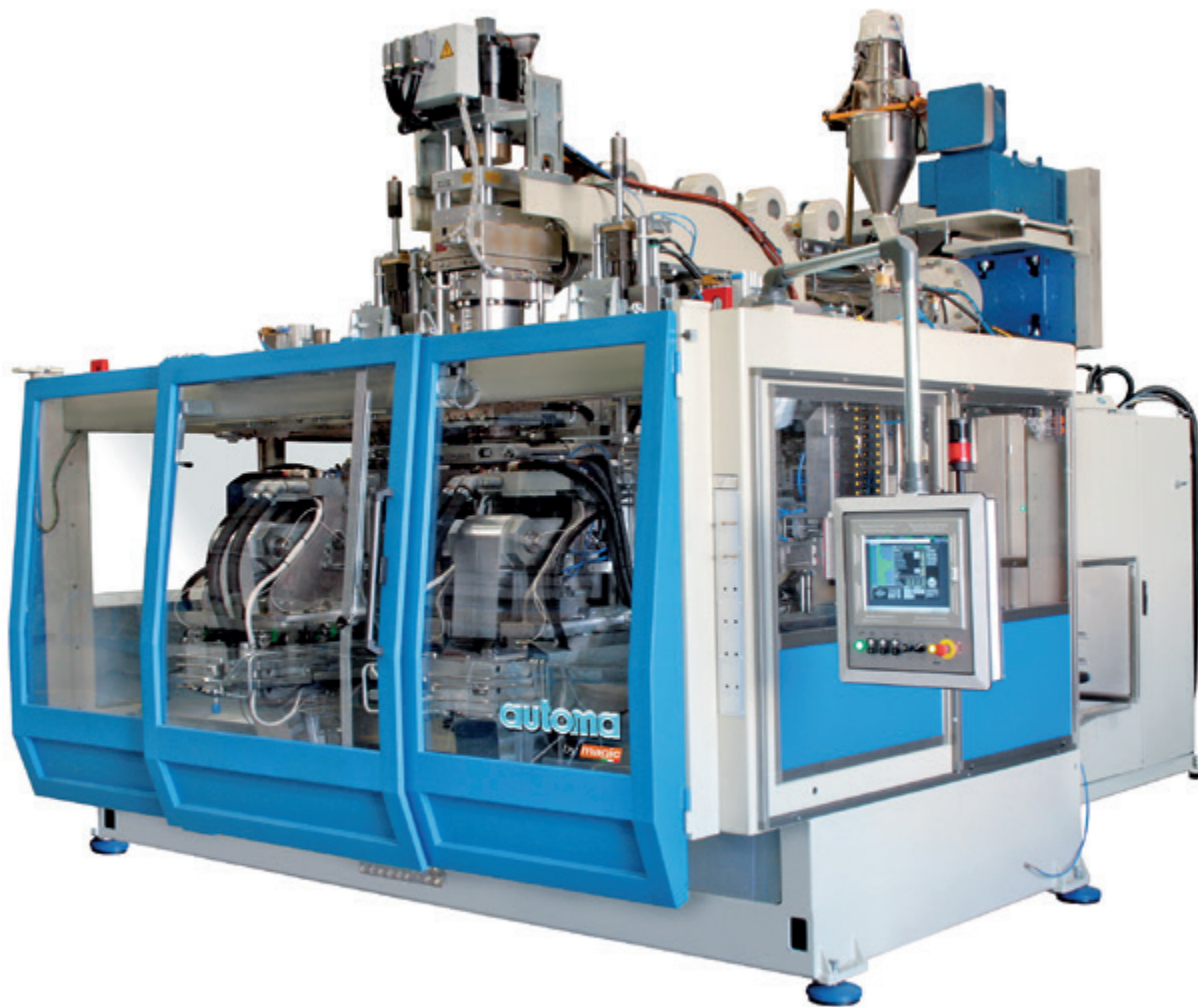

General Specifications

	US				Metric			
Carriage Horizontal Shuttle Stroke	28 inches				700 mm			
Dry Cycle	3.300s				3.300s			
Clamp Force	33 US tons				300 kN			
Air Pressure	87 -116 psi				6 - 8 bar			
Air Consumption (Estimated)	106 cfm				3000 lt/min			
Hydraulic Cooling Capacity	47,587 btu/hr				12,000 kcal/hr			
Mold Cooling Capacity	674 btu/hr (HDPE)				170 kcal/hr (HDPE)			
Water Cooling Pressure (Min)	58 psi				4 bar			
Pump Motor Power	40 hp				30 kW			
Total Power Installed (Estimated)	235 kW				235 kW			
Dimensions	197 x 236 x 156 inches				5000 x 6000 x 3950 mm			
Total Weight	51,808 lbs				23,500 kg			
Production Possibilities								
CAVITIES	1	2	3	4	1	2	3	4
Max Center	-	13 inches	9 inches	6 inches	-	320 mm	215 mm	160 mm
Max Container Width	13 inches	11 inches	7 inches	5.7 inches	340 mm	290 mm	190 mm	145 mm
Max Container Height	17 inches	17 inches	14 inches	14 inches	420 mm	420 mm	350 mm	350 mm
Max Container Depth	12 inches	-	-	-	315 mm	-	-	-
Container Capacity Approx	8 gals	3 gals	1 gals	.5 gals	30 L	10 L	5 L	2 L
Extruders	110/24D	110/25D	120/24D		110/24D	110/25D	120/24D	
Screw Diameter	4 inches	4 inches	4 inches		110 mm	110 mm	110 mm	
Extruder Motor Power	147 hp	147 hp	153 hp		110 kW	110 kW	114 kW	
Max Throughput = PE	661 lbs/hr	705 lbs/hr	882 lbs/hr		300 kg/hr	320 kg/hr	400 kg/hr	
Max Throughput = PP	573 lbs/hr	573 lbs/hr	661 lbs/hr		260 kg/hr	260 kg/hr	300 kg/hr	
Heating Power	32.5 kW	37.6 kW	43.7 kW		32.5 kW	37.6 kW	43.7 kW	
Clamping								
Max Width (A)	27 inches				695 mm			
Min Length (B)	26 inches				650 mm			
Minimum Depth (C)	8 inches				200 mm			
Clamp Open Max Daylight (D)	29 inches				740 mm			
Open Stroke (E)	13 inches				340 mm			
Mold Weight Max	1543 lbs				700 kg			

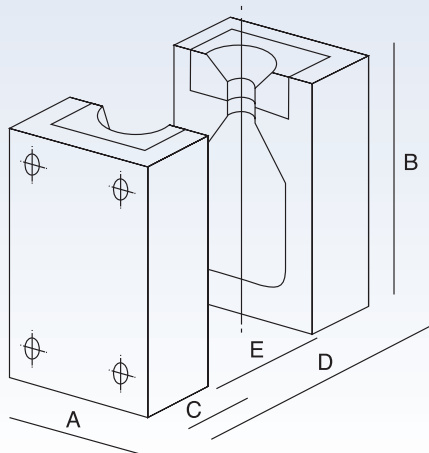

Jomar[®]

Exclusive North American Distributor
of Automa EBM Machines

automa by **magic**

115 East Parkway Drive
Egg Harbor Township, NJ 08234 USA
1-609-646-8000
jomarcorp.com
sales@jomarcorp.com