

Continuous Extrusion Shuttle Blow Molding Machine

For Production of Plastic Containers

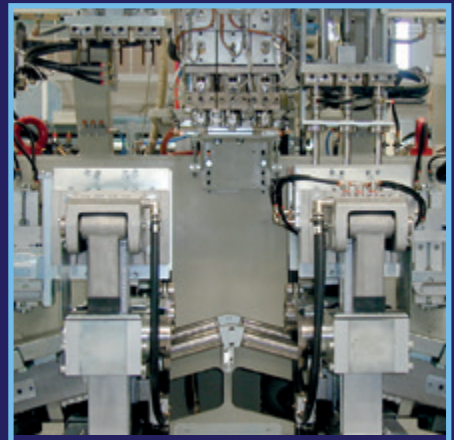

General Specifications

	US						Metric							
Carriage Horizontal Shuttle Stroke	14.4 inches						365 mm							
Dry Cycle	1.800s						1.800s							
Clamp Force	8 US tons						70 kN							
Air Pressure	87 -116 psi						6 - 8 bar							
Air Consumption (Estimated)	42 cfm						1200 lt/min							
Hydraulic Cooling Capacity	13,880 btu/hr						3500 kcal/hr							
Mold Cooling Capacity	674 btu/hr (HDPE)						170 kcal/hr (HDPE)							
Water Cooling Pressure (Min)	44 psi						3 bar							
Pump Motor Power	12 hp						9 kW							
Total Power Installed (Estimated)	70 kW						70 kW							
Dimensions	100.4 x 157.5 x 126 inches						2550 x 4000 x 3200 mm							
Total Weight	12,348 lbs						5600 kg							
Production Possibilities														
CAVITIES	1	2	3	4	5	6	1	2	3	4	5	6		
Max Center	–	5.9 inches	4.3 inches	2.8 inches	2.4 inches	2.0 inches	–	150 mm	110 mm	70 mm	60 mm	50 mm		
Max Container Width	7.5 inches	5.3 inches	3.5 inches	2.4 inches	2.0 inches	1.6 inches	190 mm	135 mm	90 mm	60 mm	50 mm	40 mm		
Max Container Height	12.4 inches	11.8 inches	11 inches	11 inches	11 inches	9.8 inches	315 mm	300 mm	280 mm	280 mm	250 mm	250 mm		
Max Container Depth	5.3 inches	–	–	–	–	–	135 mm	–	–	–	–	–		
Container Capacity Approx	1.3 gals	.3 gals	.3 gals	.2 gals	.1 gals	.09 gals	5 ml	1 L	1 L	.75 L	.5 L	.33 L		
Extruders			60/24D			70/24D			60/24D			70/24D		
Screw Diameter	2.4 inches			2.8 inches			60 mm			70 mm				
Extruder Motor Power	32 hp			49 hp			23.5 kW			36.5 kW				
Max Throughput = PE	132 lbs/hr			243 lbs/hr			60 kg/hr			110 kg/hr				
Max Throughput = PP	101 lbs/hr			187 lbs/hr			46 kg/hr			85 kg/hr				
Heating Power	11.7 kW			13.1 kW			11.7 kW			13.1 kW				
Clamping														
Max Width (A)	14.4 inches						365 mm							
Min Length (B)	14.8 inches						375 mm							
Minimum Depth (C)	3.9 inches						100 mm							
Clamp Open Max Daylight (D)	14.2 inches						360 mm							
Open Stroke (E)	6.3 inches						160 mm							
Mold Weight Max	221 lbs						100 kg							

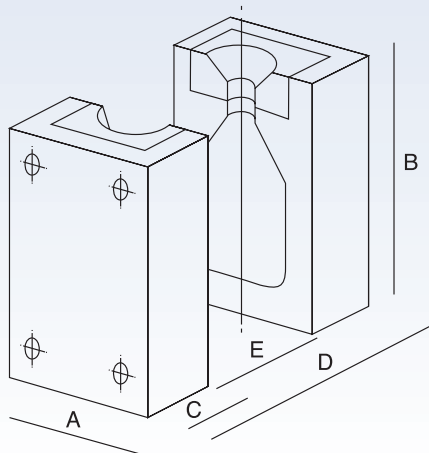

Jomar[®]

Exclusive North American Distributor
of Automa EBM Machines

automa by *magic*

115 East Parkway Drive
Egg Harbor Township, NJ 08234 USA
1-609-646-8000
jomarcorp.com
sales@jomarcorp.com